

MANISCOPIC

MHT 10120 L

Turbo



- Capacity : 12000 kg
- Lift height : 9.62 m
- Engine : 175 HP
- 4 wheel steer – 4 wheel drive
- Hydrostatic transmission
- Frame levelling 10°/10°

 **MANITOU**

MHT 10120 L TURBO

LOAD CENTRE AT 600 MM

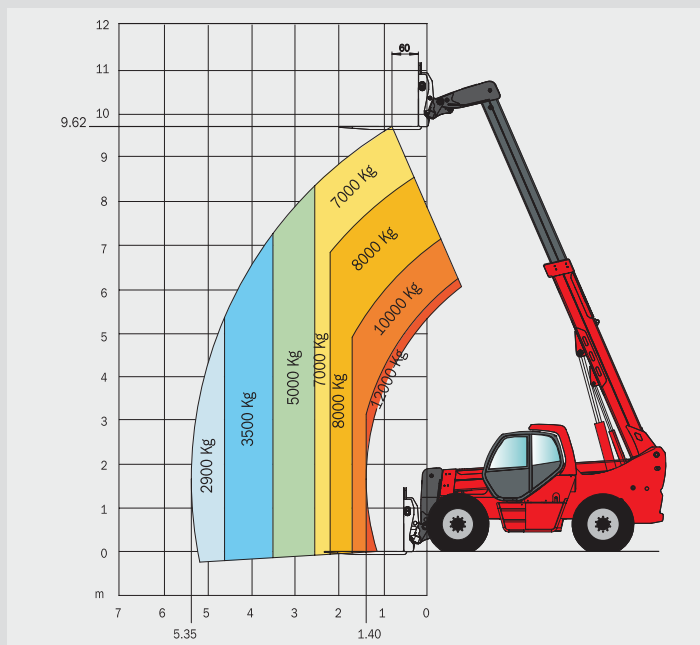

LOAD CENTRE AT 1200 MM

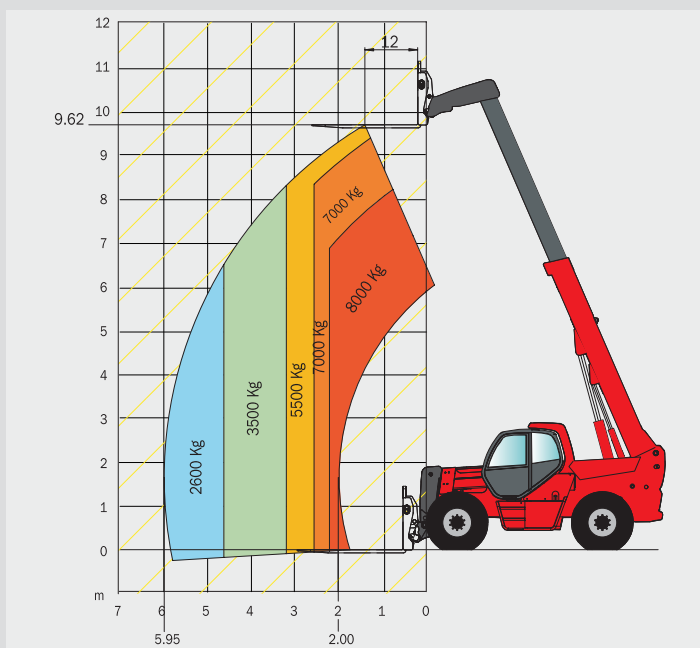

ENGINE

Diesel MERCEDES OM 904 LA Turbo – Intercooler – Air / Air

Capacity : 4 cylinders / 4250 cm3
 Power (ISO/TR 14396) : 175 HP / 129 kw
 Rated speed : 2200 r.p.m.
 Maximum torque at 1200 r.p.m. : 675 Nm

Electronic injection (4 injection pumps and 4 injectors)

Fan : puller
 Cooling : water

Water radiator, with double-speed hydraulic fan (2000 to 3000 r.p.m.)

Anti-polluting standards : EUR2
 Air filter (type / micron) : cartridge / 3
 Battery : 12 Volts
 Capacity : 120 Ah

LIFT CAPACITY / HEIGHT

Load centre	at 600 mm	at 1200 mm
Lift capacity :	12000 kg	8000 kg
Capacity at max. height	7000 kg	5500 kg
Capacity at max. front reach :	2900 kg	2600 kg
Lift height :	9.62 m	9.62 m
Maximum front reach :	5.35 m	5.95 m

TRANSMISSION

Hydrostatic transmission **REXROTH**

Hydrostatic variable flow pump : 71 cm³
 Hydrostatic variable cylinder engine : 140 cm³
 Reversing shift : electro-magnetic
 Differential central : NO

2 forward and reverse speeds :

Low speed : 10 km/h
 Fast speed : 25 km/h

HYDRAULICS

Main pump : Piston Load Sensing Haute pression

Capacity : 75 cm³
 Maximum pressure : 350 bar
 Flow : 165 L/mn
 Max. flow on attachment (at 350 bar) : 140 L/mn

Steering pump

Type : Load sensing
 Maximum pressure : 180 bar

Power brake circuit pump

Type : **REXROTH**
 Capacity : 18.7 cm³
 Maximum pressure : 40 bar
 Flow : 41 L/mn

Hydraulic oil radiator

2 continuous fans
 2 automatic fans

Distributor : Big flow hydraulic proportional REXROTH (280 to 300 L/mn) with 4 closed centre elements

Drive Type :

Proportional hydraulic joystick with 3 movement combination

- 1- Lifting / Crowding
- 2- Boom extension / Attachment
- 3- Lifting / Boom extension

Flexibles

TP tube type with high pressure type flexible links

Filtration degree (micron) :

Suction : 250 mic
 Return : 10 mic
 Filtration air tank : 10 mic

DIAGRAMS

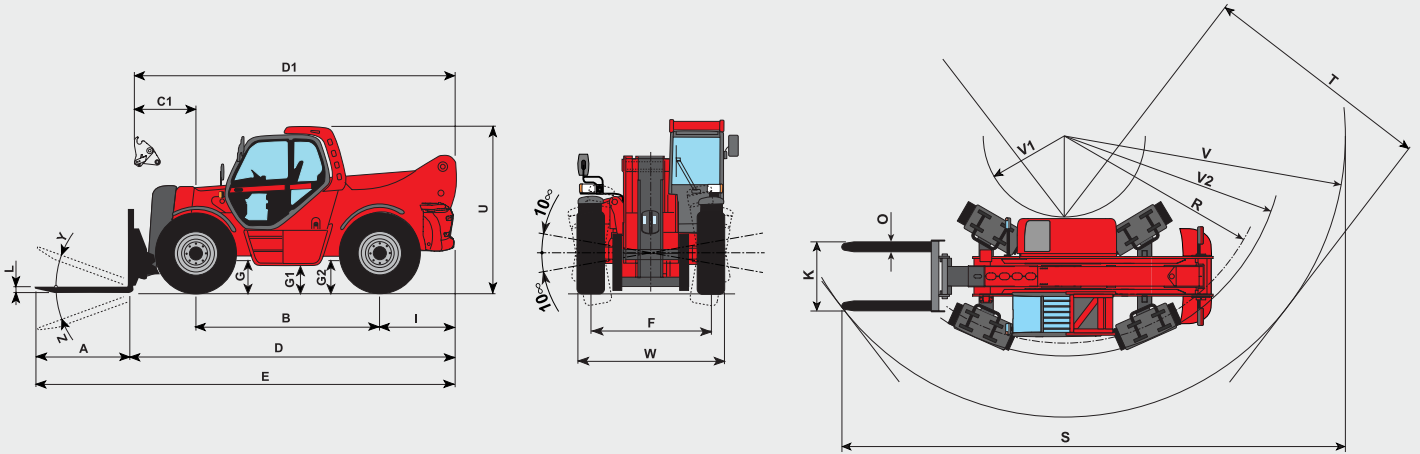

A	B	C	D	E	F	G	G1	G2	I	K	L	M	O	R	S	T	U	V	V1	V2	W	Y	Z
1800	3300	1115	5950	7750	1956	550	445	550	1425	1430	70	2300	200	4233	9205	4615	2900	5868	1690	4528	2400	20°	115°

AXLES

HURTH "Heavy Duty", oil bath with epicycloidal reduction with 4 satellites Integrated steering cylinders with double action in high position

Frame levelling 10°/10° on front axle

3 steering modes:

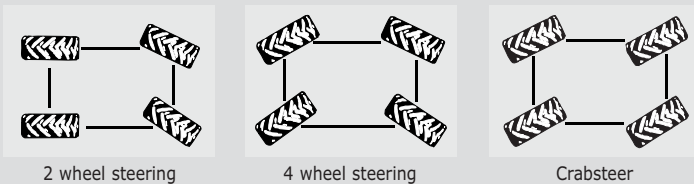

BRAKES

Type : oil bath multidisc
 Drive type : hydraulic
 On axle : front + rear

Parking brake on front and rear axles :
 Oil bath multidisc negative parking brake

TYRES

Model : 17.5 - 25
 Pressure : 7 bar
 Drawbar pull : 11300 daN

LIFTING/TELESCOPING MOTIONS

Unladen lifting : 13 sec
 Unladen lowering : 9 sec

Unladen extending internal telescope : 14.5 sec
 Unladen retracting internal telescope : 9 sec

FORKS

Standard equipment TFF 10750
 Dimensions : 200 x 80 x 1500 mm
 Weight of forks : 560 kg

CAPACITIES

Cooling circuit : 16 L
 Engine oil : 8.1 L
 Equipment hydraulic oil : 290 L
 Fuel tank : 200 L

WEIGHT

Total weight without equipment : 15900 kg
 Total weight unladen with forks : 17000 kg
 Total weight laden with forks : 29000 kg

Load on axle with standard equipment (unladen)

On front axle, boom retracted : 6350 kg
 On rear axle, boom retracted : 10650 kg

Load on axle with standard equipment (laden)

On front axle, boom retracted : 25000 kg
 On rear axle, boom retracted : 4000 kg

STANDARD EQUIPMENTS

- ROPS-FOPS cabin
- GRAMMER seat
- Front and rear wipers
- Driving lights
- Rotating beacon
- Left rearview mirror
- Safety device with automatic lock of aggravating movements
- Safety valves on cylinders
- Heating

OPTIONS

- Air conditioning
- Comfort seat
- Roof wipers
- Cabin rearview mirror



Manitou, material handling world leader

Inventor of the rough terrain forklift truck, Manitou offers today the most comprehensive range to meet all specific handling and personal lifting requirements :



Telescopic trucks

MANISCOPIC

Rough terrain and semi industrial masted trucks

MANITOU



Access equipment

MANIACCESS

Compact telescopic handler

Twisco



Truck mounted forklifts

MANITRANSIT

Backhoe/Loader with telescopic boom

MANIHOE

Swinging arm and articulated wheeled loaders

MANILOADER

Electric pallet trucks and electric stackers

MANILEC



A network of skilled professionals at your service

With a network of 500 service and parts centres in more than 100 countries, Manitou provides an efficient after-sales support based on the expertise of 2000 factory trained technicians.



The equipment supplied with each model may differ from that described in this leaflet. For more details, contact your MANITOU dealer.

MANITOU BF SA

B.P. 249 - 44158 Ancenis Cedex - France
Tél. : 33 2 40 09 10 11 / Export Department Fax : 33 2 40 09 10 97
www.manitou.com

700016EN



MANITOU